

US Hybrid C-band Telemetry Proof of Concept

Darrell Ernst

May 2002

Presented at International Consortium
for Telemetry Spectrum

ETC 2002

Garmisch, Germany

MITRE

Agenda

- What is Hybrid C-Band Telemetry (HCBT)?
- Why HCBT?
- Limitations of HCBT
- HCBT Proof of Concept Test
- Status

Hybrid C-Band Telemetry

HCBT is the simultaneous use of C-band and either L-band or S-band for telemetry data transmission.

- L-Band/S-Band signal is used for tracking
- L-Band/S-Band signal may or may not be modulated, depending on capacity requirements
- Single ground antenna used to receive both signals

Why HCBT?

- Link capacity requirements growing exponentially in US
- WRC 05/06 Agenda Item 2.12 proposes spectrum for wideband telemetry in the 3 to 30 GHz region
- ~~ICTS members in agreement that allocation should be below 10 MHz~~
- International band for mobile communications already exists between 4.4 and 4.94 GHz
- ~~Several wideband data links operate now or in past in this band~~
 - ~~NASA/Dryden UAV video data link~~

Limitations of HCBT

- Tracking precision may not be sufficient in high dynamic flight
- Multipath fading characteristics at low altitudes/low elevation angles not well known
- Requires dual telemetry RF system on test vehicle
- ~~Power and space constraints~~
- Transmit antenna issues not fully resolved
- ~~High power diplexers vs. antenna spacing~~

HCBT Proof of Concept Test

Airborne Configuration

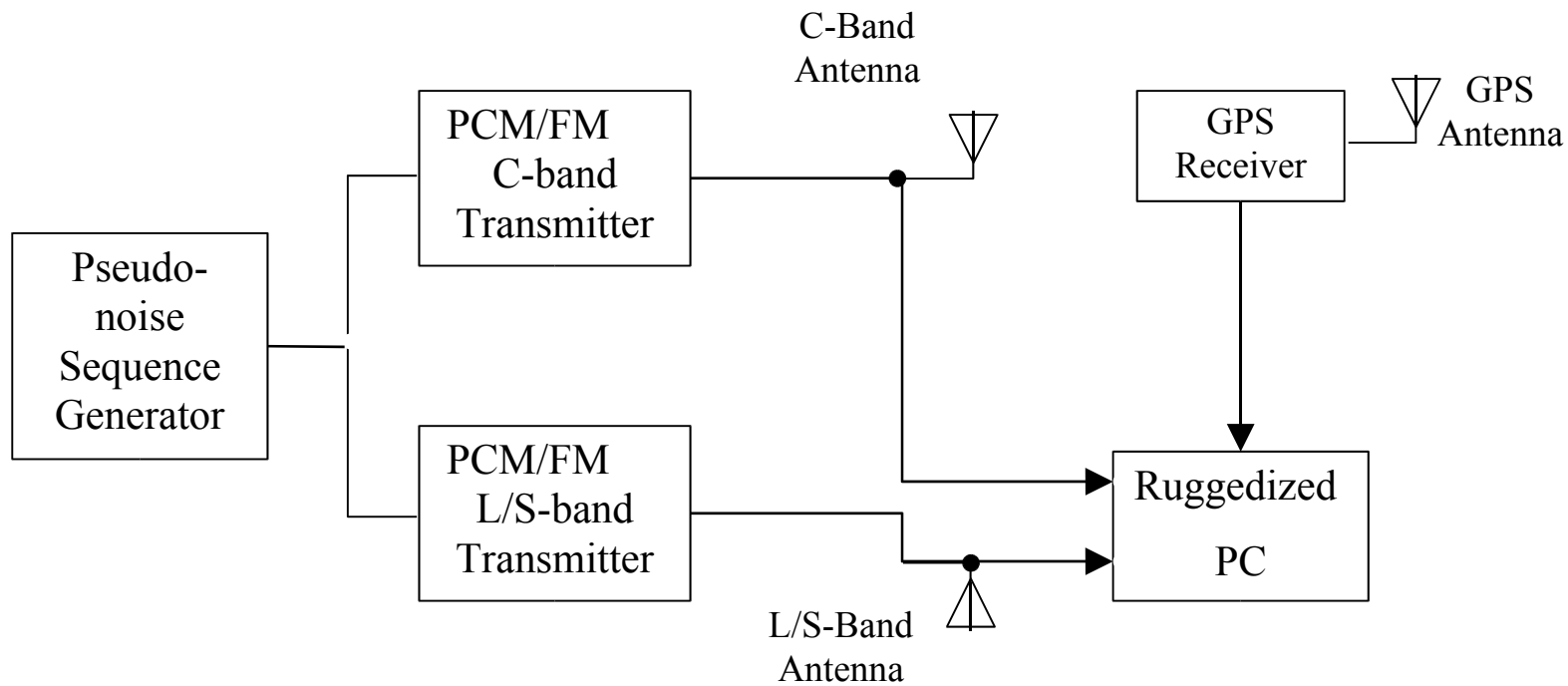
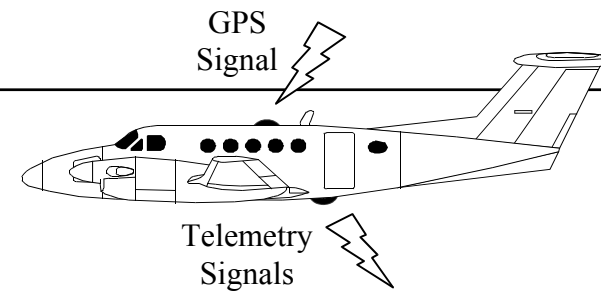

HCBT Proof of Concept Test (Concluded)

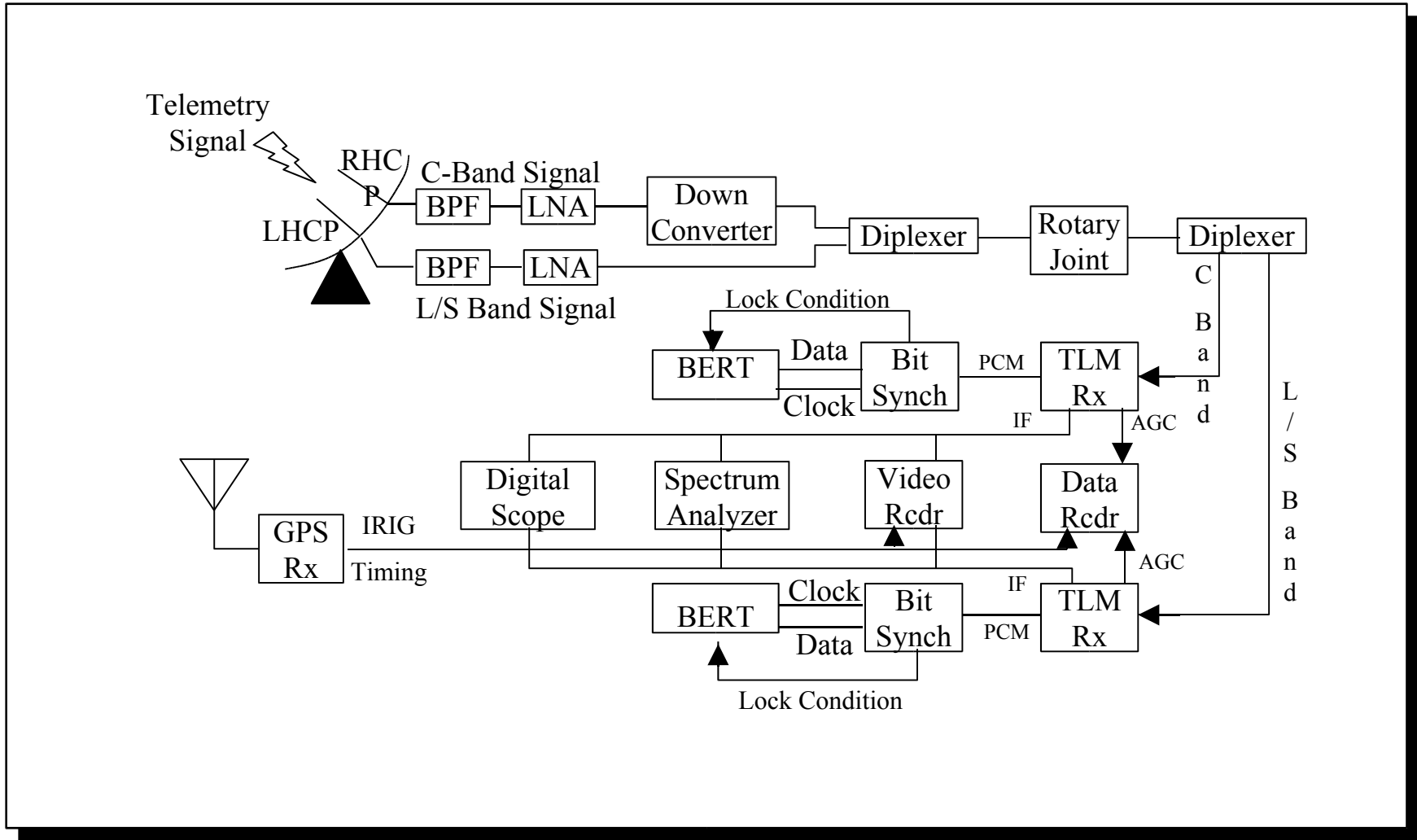

HCBT Proof of Concept Test Status

- Assigned to ARTM Project Office
- Preliminary planning complete
- Final funding approval awaiting formal submission of cost estimate

- Would like to have some flight data results to report at ICTS meeting in San Diego in October